

TECHNICAL REVIEW

Alloy Development for Transportation in Sumitomo Light Metal*

Hideo Yoshida**

Sumitomo Light Metal (SLM) has been developing high strength aluminum alloys. Dr. Igarashi at Sumitomo Metal invented the highest strength aluminum alloy in the world, ESD (Extra Super Duralumin) in 1936. This alloy, Al-8%Zn-1.5%Mg-2.0%Cu-0.5%Mn, containing 0.25% chromium that prevented SCC was immediately applied to the main wings of Zero fighters in World War II. After WWII, SLM invented a fine-grained 7075-O sheet for the taper-rolled stringer of aircraft with MHI, which was applied to commercial B767 and B777 airplanes. This sheet grain refining technology was also applied to superplastic sheets of 7475 and 8090. Recently, the 2013 alloy was developed to save the cost of fabrication with KHI. The 2013-T6 sheet has high strength compared to 2024-T3. This alloy has higher formability in T4 than 2024-T3. Therefore, this alloy sheet can be formed in T4 followed by artificial aging. Furthermore, this alloy can be extruded into hollow shapes with thin walls by porthole dies and contributes to fabricating integrated parts without seams. In motorcycles and railway cars, a weldable alloy 7003, Al-6%Zn-0.75%Mg-0.15%Zr, with higher extrudability, lower quench-sensitivity and medium strength comparable to 6061-T6 was invented in 1967 by Baba at SLM and applied to the Series 200 Shinkansen and motorcycle parts. Alloy 6N01, which can be extruded into hollow cross-section shapes with thin walls, was also developed for the 300 and 700 Series Shinkansen. In motorcycles, especially, motocross, high strength aluminum alloys with tensile strength, more than 600MPa, have been developed for the outer tube of the front forks. In automobiles, especially, aluminum body panels for hoods, the Al-4.5%Mg alloy containing zinc and copper was invented and adopted to the hood of the Mazda RX-7 in 1986 for the first time in Japan. The Al-4.5%Mg-Cu (5022) and Al-5.5%Mg-Cu (5023) alloys were then developed from the viewpoint of formability. For the Al-Mg-Si alloys, new processes were invented to improve the bake hardenability at 170°C or to improve the hem formability. To increase the formability of aluminum alloys, superplastic forming has also been applied to the hard top roof of Honda's S2000 and the fender and trunk lid of Honda's New Legend (Acura RL) using the 5083alloy.

1. Introduction

Many big companies manufacturing transportation, airplanes and aerospace, railway cars, motorcycles, and automobiles are situated in the Tokai area, the midland of Japan. In World War II (WWII), Sumitomo Metal established a new aluminum manufacturing plant (now, Sumitomo Light Metal) in Nagoya

to provide aluminum products for aircraft manufacturing companies. After WWII, SLM has been developing new aluminum alloys and providing aluminum products for companies manufacturing railway cars, motorcycles and automobiles for fifty years. In this review, the history of Extra Super Duralumin (ESD), which alloy has been our identity, is first described. The topics of research and development of aluminum alloys for aircraft at SLM after WWII are then shown. Third, the R&D of Al-Mg-Si and Al-Zn-Mg alloy extrusions for railway cars and motorcycles is summarized. Finally, the recent R&D for the

* This paper was presented as an invited lecture at the 12th International Conference on Aluminium Alloys (ICAA12), Yokohama, Japan, September, 5-9, 2010.

** R&D Center, Sumitomo Light Metal Ind. Ltd., Dr. of Eng.

body panels of automobiles is introduced¹⁾.

2. History of Extra Super Duralumin (ESD) for aircraft

In 1916, the Japanese Imperial Navy obtained part of the frame of the Zeppelin Airship shot down in the suburb of London and ordered an analysis of the frame shown in Fig. 1 by Sumitomo (Sumitomo Copper Rolling Works). On the basis of these results, Sumitomo tried to produce the Duralumin sheet in 1919. After WWI, to learn the technology of aluminum production as compensation for the war, in 1922, Sumitomo sent four engineers with military personnel to Dürerer Metallwerke AG, which produced Duralumin. Based on this technology, in 1935, Sumitomo developed Super Duralumin similar to Alcoa alloy 2024. In this year, Igarashi (Fig. 2) and his co-workers at Sumitomo Metal made a start on the development of higher strength alloy than Super Duralumin at the request of the Navy. As a result, they invented a new alloy (Al-8%Zn-1.5%Mg-2%Cu-0.5%Mn-0.2%Cr) with the high tensile strength of 600MPa based on the E alloy (Al-20%Zn-2.5%Cu-1.5%Mg-0.5%Mn), S alloy (Al-8%Zn-1.5%Mg-0.5%Mn) and Super Duralumin (Al-4%Cu-1.5%Mg-0.5%Mn) and immediately made a patent application in 1936. This alloy, named ESD (Extra Super Duralumin) after E alloy, S alloy and Duralumin, had chromium to prevent season cracking (now known as stress corrosion cracking).

At that time, the cause of season cracking was not clear. Igarashi recognized the influence of the tensile stress and corrosive environment such as sodium chloride solution on the season cracking. Therefore, he devised the several test procedures shown in Fig. 3 to evaluate the lifetime to crack in Al-Zn-Mg-Cu alloys containing several additional elements²⁾. These tests showed that the cracking was grain boundary embrittlement and the addition of chromium was the most effective to prevent the cracking. He thought the cause of cracking was inter-granular corrosion and the addition of chromium and manganese reduced the intergranular corrosion. He also found that the excess addition of chromium caused the

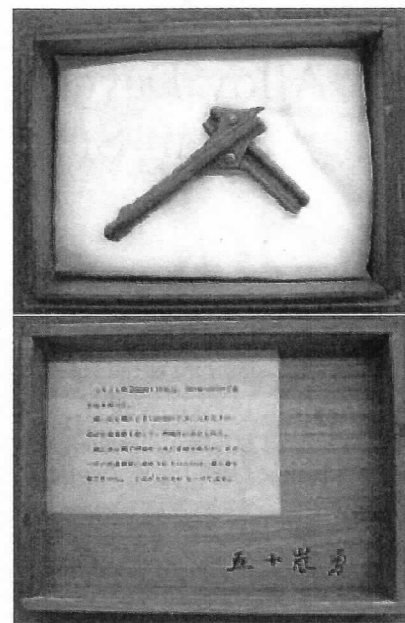

Fig. 1 Part of the frames of Zeppelin Airship shot down at London, brought into Japan and stored in SLM.



Fig. 2 Dr. Igarashi, the inventor of ESD.

occurrence of giant compounds combined with manganese during solidification, and these compounds reduced the fatigue strength.

The ESD alloy extrusion and clad sheet were used for the main wings of the Zero Fighter shown in Fig. 4 in 1938. To produce aluminum sheets, extrusions and forgings for aircraft, the Nagoya Work of Sumitomo Metal was built in 1941 near the Mitsubishi Heavy Industries (MHI) and aluminum products of about 4000 ton per month were manufactured. At the same time, Alcoa also investigated the stress

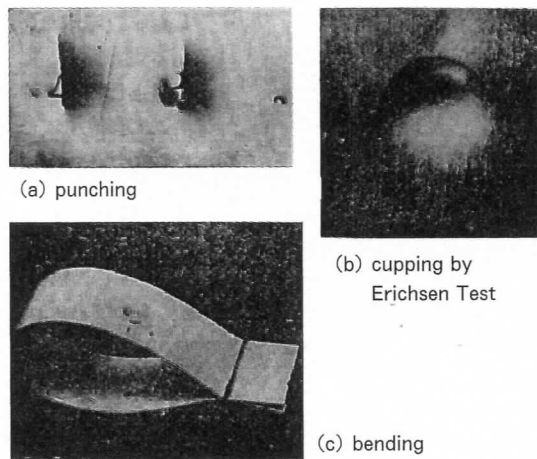

Fig. 3 Test procedure of stress corrosion (season cracking) devised by Igarashi and Kitahara.

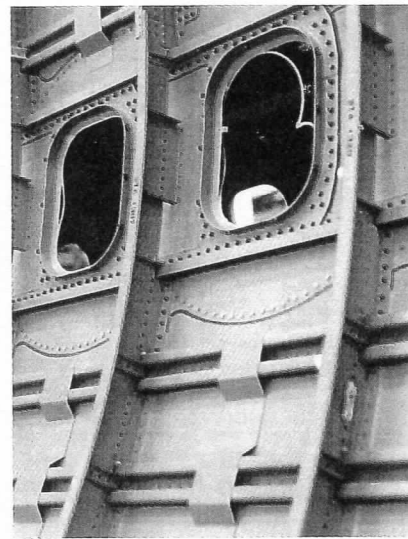

Fig. 5 Fuselage of the Boeing 767.



Fig. 4 Zero Fighter and its main wing structure.

corrosion resistance of the Al-Zn-Mg-Cu alloys and introduced alloy 7075 with chromium in 1943³⁾.

3. Aircraft

3.1 Taper-rolled stringer of 7075 alloy

In Japan, the R&D and manufacturing for aircraft were prohibited for a while after WWII. However, the Japanese aircraft industries have been reestablished through the production of a Japanese airplane, the YS11, and subcontracting the fuselage of Boeing's airplanes. During manufacturing the fuselage of the Boeing 767 shown in Fig. 5, Baba and Uno at SLM invented the grain-controlled 7075 alloy sheet for the taper-rolled stringers in 1979.

The taper rolled stringer has a variable thickness in the rolling direction shown in Fig. 6, because the thickness of the stringer at the joint to frame needs to be thick and the other to be thin to reduce the weight. For producing the taper rolled stringer, the O-tempered 7075 alloy sheet is used and is cold-rolled from 0 to 80% reduction followed by solution heat treatment. In solution heat treatment, the grain growth occurred in the small reduction of about 10 to 20% and caused a crack during the roll-forming into hat shapes or a reduction in the fatigue strength. MHI requested us to develop the sheet without grain growth at the small reduction in solution treatment. Baba et al. invented a new process including grain refining by rapid heating and cooling followed by overaging. Fig. 7 shows the effect of the cold rolling on the grain size of the stringer produced by newly developed and conventional process⁴⁾.

3.2 Superplasticity of 7075 and Al-Li alloys

The grain size of a stringer rapidly-heated at solution temperature is from 30 to 50 μm in Fig. 7. However, to get more fine grains of about 10 μm , the size control of the precipitates before rolling was needed as described by Paton et al. at Rockwell International Corp., in 1978⁵⁾. Their grain refinement process included solution heat treatment, overaging, quenching, warm rolling and recrystallization. In the commercial process, it is difficult to quench a coil to the aging temperature and then warm rolling, so another process instead of Rockwell

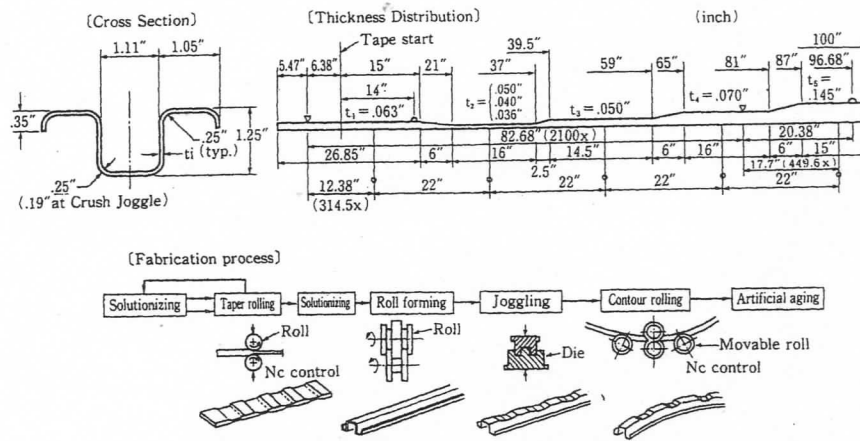

Fig. 6 Thickness distribution and fabrication process of taper rolled stringer.

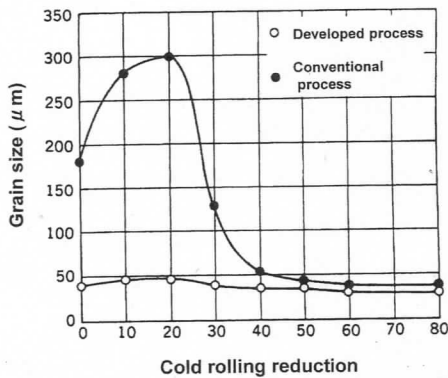

Fig. 7 Effect of the cold rolling reduction on the grain size of stringer produced by newly developed and conventional processes.

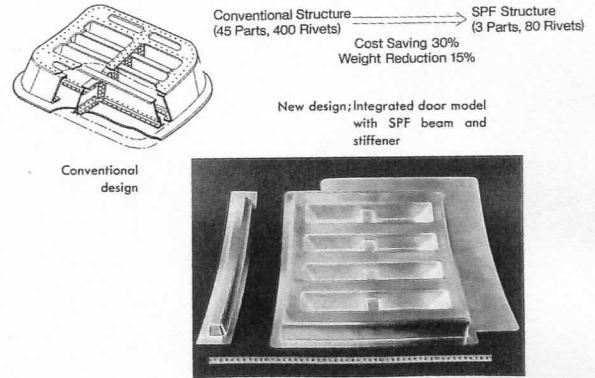

Fig. 8 Integrated door with beam and stiffener deformed by superplastic forming compared to a conventional structure.

International's process was required. In 1983, a new process was invented including heating the coil at more than 400°C followed by furnace cooling, then, cold rolling at the reduction of more than 70% and finally rapid heating to 480°C. The sheet produced by SLM was superplastically formed in MHI as shown in Fig. 8⁶⁾.

Next we tried to produce the superplastic sheet of the Al-Li alloys 8090 and 2090 in the laboratory. However, it was hard to hot-roll Al-Li alloys because of cracking and the Al-Li sheet produced by the above mentioned process had a significant anisotropy in superplasticity shown in Fig. 9. To improve the workability and anisotropy, sufficient precipitation at the precipitation nose of the T_2 ($Al_6Cu(Li, Mg)_3$) phase and isothermal rolling at this temperature were performed. The sheet produced by this warm rolling process had

isotropy as shown in Fig. 9 and showed higher strain rate superplasticity than the 7075 alloy because more finer grains than the 7075 alloy occurred during the superplastic deformation by dynamic recrystallization⁶⁻⁸⁾.

3.3 Alloy 2013

In recent years, the cost reduction to manufacture airplanes has been required. For this request, SLM invented a new alloy registered as AA2013 (Al-1.7%Cu-1%Mg-0.85Si-0.16%Cr) with Kawasaki Heavy Industries (KHI). This alloy sheet has the same strength in T6 temper as 2024-T3 and higher formability in T4. Thus it is possible to form the sheet as T4 followed by artificial aging. This manufacturing process contributes to cost savings because it does not need the quenching of formed parts and the stress relief from them.

This alloy can be also extruded in hollow sections with thin walls like the Al-Mg-Si

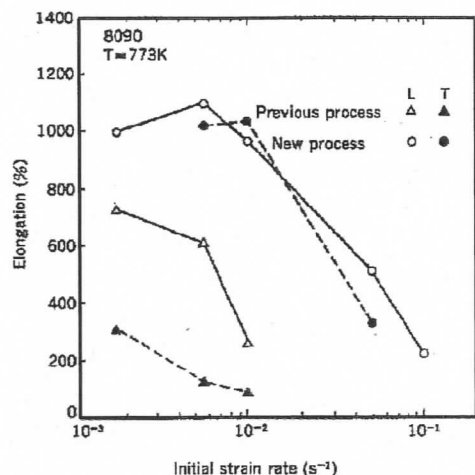

Fig. 9 Superplasticity of 8090 produced by warm rolling compared with conventional process.

alloys. Fig. 10 shows the application of the alloy 2013 extrusions to integrated structures in a pressure deck beam and a window frame. In this case, the cost reduction is expected to be 72% of the conventional construction method^{9,10}.

4. Railway Cars

4.1 Al-Zn-Mg alloy, 7N01, 7003

Aluminum railway cars were introduced with a welded structure of skin (5083 sheet), frame (5083 extrusion) and underframe (6061 extrusion) joined with rivets and bolts in 1962. In the middle of the 1960's, a new weldable Al-Zn-Mg alloy, JIS A7N01, was developed and its extrusions were used for the underframe. Thus, all welded aluminum railway cars were manufactured and introduced in subways.

In 1942, the HD alloy (Honda Alloy, Al-5.5%Zn-2%Mg-0.75%Mn-0.25%Cr) was developed for extrusion because it had better extrudability compared to SD and ESD. However, at that time, rivet joining was mainly used. After World War II, TIG and MIG welding were developed and this alloy was considered a weldable alloy because the weld joint had a high strength due to natural age hardening after welding. Thus, the Al-4.5%Zn-1.5%Mg-0.45%Mn-Cr alloy similar to AA7004 and 7005 was registered as JIS A7N01.

In extrusion alloys, quench sensitivity is an important factor for high productivity. Baba showed that the addition of zirconium was less

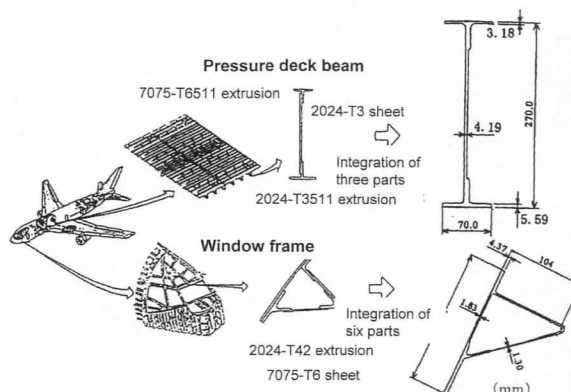

Fig. 10 Applications of new alloy 2013 extrusions to integrated structures in a pressure deck beam and a window frame.

sensitive to quenching than chromium and was effective for preventing the weld crack. The reason for being more sensitive by the addition of chromium was that second-phase particles containing chromium were a stable phase and the interface is non-coherent with a matrix, so η -phase easily precipitates at the interface during quenching, while the precipitates containing zirconium have the $L1_2$ structure and are coherent with a matrix. Therefore the precipitation does not easily occur during quenching¹¹. Further, the addition of zirconium to the Al-Zn-Mg alloys causes a more fibrous structure and prevents the occurrence of grain growth during extrusion or solution heat treatment compared to chromium. As a result, weld cracking or stress corrosion cracking is prevented. On the basis of these studies, Baba invented a new Al-Zn-Mg alloy with zirconium instead of chromium in 1965¹². Furthermore he found that a small amount (0.15%) of added copper was effective for stress corrosion cracking in the short transverse direction. These Sumitomo alloys are called ZK47 and ZK141.

To extrude shapes with high extrudability and thin thickness, a new alloy, Al-6%Mg-0.8%Mg-0.25%Mn-0.17%Zr (Sumitomo ZK60), which has a higher content of zinc and lower one of magnesium compared with 7N01, was invented by Baba et al. in 1967. ZK60-T5 has medium strength compatible with 6061-T6 and this alloy was registered as AA7003 in 1975. With this invention, shapes of 500mm wide were able to be extruded at KOK having a 9500 ton press and applied to the cant rail of the Series

200 Shinkansen in 1970. Alloy 7003 was widely used for the strength member of a container, ban and trailer, rim of a motorcycle and bicycle, bumper reinforcement and etc.^{13,14)}

4.2 Al-Mg-Si alloy, 6N01

A new alloy with higher extrudability, weldability and corrosion resistance than the Al-Zn-Mg alloys was needed to reduce the initial cost compared to stainless steel. In Europe, the Al-Mg-Si alloy, 6005A was developed and used for railway cars. However, the grain growth, decreased fracture toughness and microfissure cracks in the weld easily occurred in this alloy. Therefore these problems were solved by controlling the content and the process condition, and finally JIS A6N01 was registered in 1980. This 6N01 alloy was able to be extruded in hollow sections with thin walls and was applied to the body structure of the Series 300 Shinkansen. In the 1990's, a double skin type body structure with the truss in the hollow section was applied to the Series 700 Shinkansen (Fig. 11). The body and underframe of this Shinkansen were built using only the 6N01 alloy extrusion. Recently, brazed honeycomb panels and friction stir welding technology were applied to the structure of the body and the underframe.

5. Motorcycles

The Japanese motorcycle industries have been developed since World War II and the share of them such as Honda, Yamaha, Suzuki and Kawasaki is now the largest in the world. In this development, aluminum has been used in the engine parts, like the cylinder head, case etc. In the 1980's, the weight saving and design of motorcycles were required, especially, for motor racing. As a result, the wheels, frame, swing arm and radiator were produced using aluminum shown in Fig. 12. For a spoke type wheel, the Al-Zn-Mg alloy, 7003 was used in the rim because this alloy has a medium strength and high weldability to flash butt welding. Recently, high strength Al-Zn-Mg-Cu alloys are also available for this rim.

In the front fork, which is the suspension consisting of double tubes, the outer tube (aluminum alloy) and inner tube (steel) shown

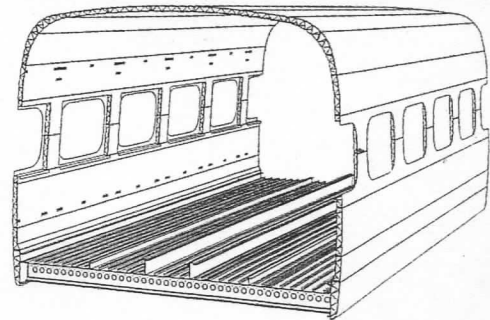
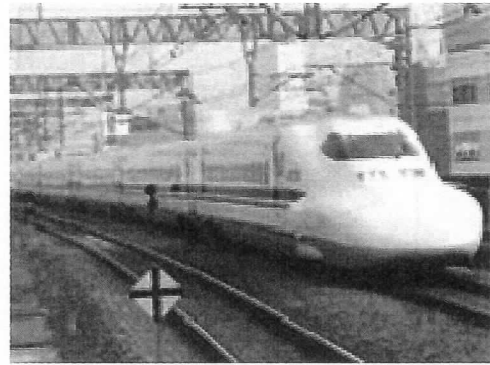

Fig. 11 Series 700 Shinkansen and its body structure produced by 6N01 hollow extrusions with truss cross sections.

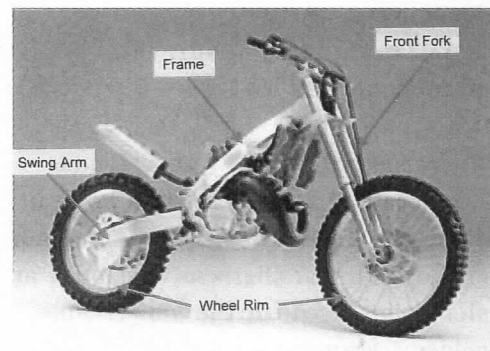

Fig. 12 Motorcycle parts using high strength wrought aluminum alloys for a motocross.

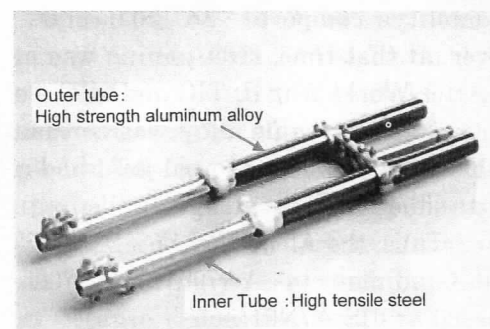

Fig. 13 Front fork of a motorcycle using a high strength wrought aluminum alloy for the outer tube.

in Fig. 13, aluminum cast alloys were previously used for the outer tube. However, in the 1990's, off road races, such as motocross, required higher strength and toughness than cast alloys in the outer tube because high impact force occurred at landing. Therefore Al-Zn-Mg-Cu alloys were adopted from the viewpoint of strength and toughness. The addition of zirconium was needed to prevent grain growth at the surface of the tube and reduce the quench sensitivity. Especially, a vertical furnace and mild quenching into polyalkylene glycol are effective for low and uniform residual stress circumferentially¹⁵⁾. Recently, a higher strength and toughness aluminum alloy, Sumitomo ZC88, was developed for this tube¹⁶⁾.

6. Automobiles, body panels

6.1 Al-Mg alloys

In the Tokai area, there are many manufacturing companies related to automobiles including the Toyota Motor Corporation. The root of this company is the production of automatic looms, and this area was the center of the spinning industries a hundred years ago.

After the oil shock in the 1970's, the application of aluminum body panels was studied to save weight and increase the fuel efficiency. First, the formability of aluminum alloys was investigated as a substitute for mild steel. As a result, Uno invented a new Al-Mg-Zn-Cu alloy, Sumitomo GZ45, with higher strength and higher elongation than AA5182 in 1978. This alloy contained 4.5%Mg, 1.5%Zn and 0.35%Cu and had a 300MPa tensile strength and 30% elongation in T4 temper¹⁷⁾. In 1986, the

GZ45 alloy sheet was adopted for the hood of the Mazda RX-7 (Fig. 14) for the first time in Japan. However, zinc was not added later because of natural age hardening which caused a reduced formability. Thus the Al-4.5%Mg-Cu alloy, Sumitomo GC45, was developed and used. The addition of copper prevents the reduction of yield strength after baking.

More formability than GC45 was required by car makers. It is well known the formability of the Al-Mg alloy increases with the magnesium content. However, the upper limit of magnesium was decided by the hot workability and stress corrosion resistance. As a result, the Al-5.5%Mg-Cu alloy, Sumitomo GC55, was developed. The Al-4.5%Mg-Cu and Al-5.5%Mg-Cu alloys were registered as AA5022 and AA5023 in AA, respectively.

6.2 Al-Mg-Si alloys

To further reduce the weight of panels, Al-Mg-Si alloys with the paint bake hardenability were needed. The temperature and time of bake was required at 170-180°C for 20-30 minutes,

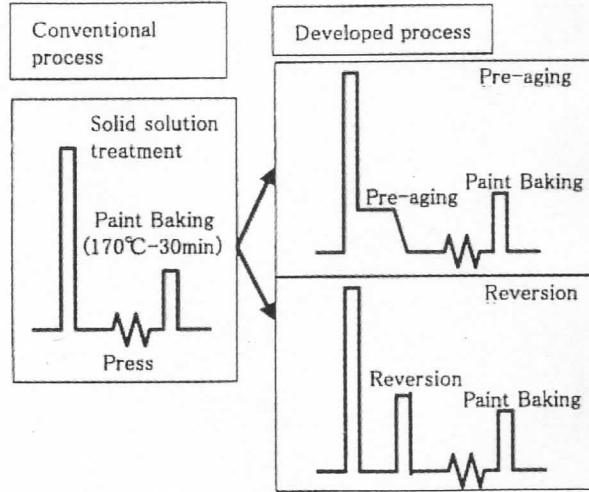

Fig. 15 New processes containing pre-aging or reversion developed for enhancement of bake hardening at 170° .

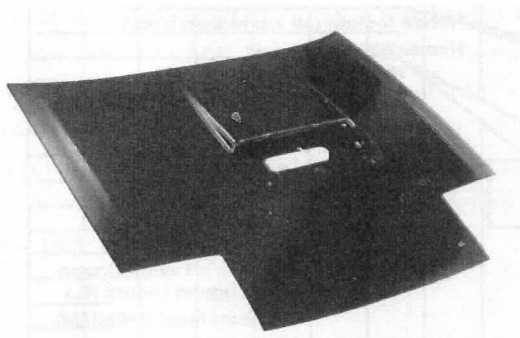
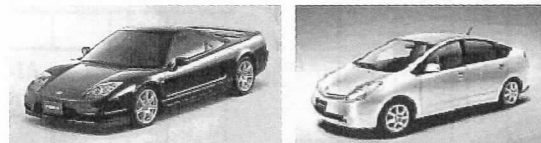

Fig. 14 Aluminum Hood of Mazda RX-7.



(a) Honda (Acura) NSX (b) Toyota Prius (Hybrid car)

Fig. 16 Japanese cars using Al-Mg-Si aluminum alloy sheets with high bake hardenability.

which was the same condition as mild steel. It is well known that it is necessary to increase the temperature up to 200°C to bake Al-Mg-Si alloys for such a short time. Therefore, the control of the content and heat treatment was studied for bake hardening at a low temperature. As a

result, the new processes shown in Fig. 15 were developed for the Al-Mg-Si alloy with excess Si¹⁸⁾. One is pre-aging near 100°C immediately after quenching and the other is reversion. In each process, the Mg-Si clusters formed at room temperature were diminished. These clusters are

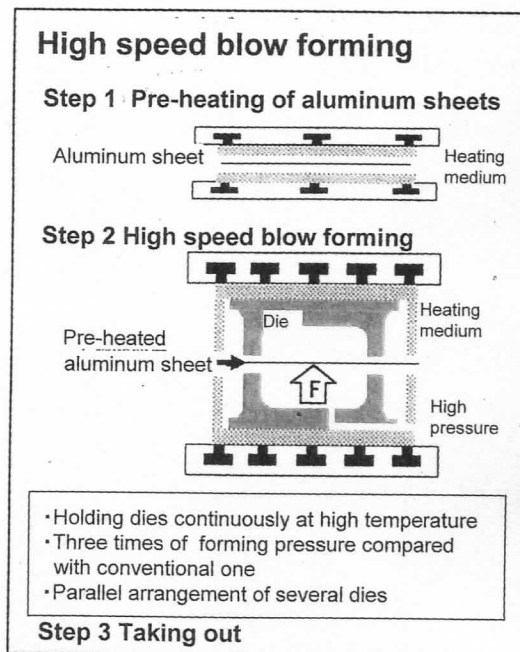
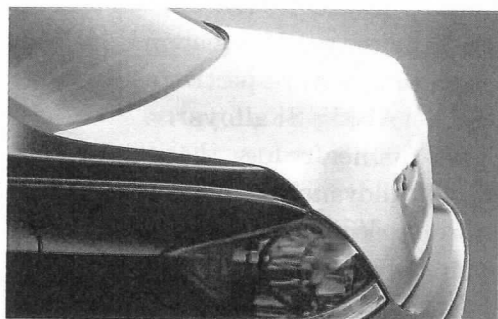
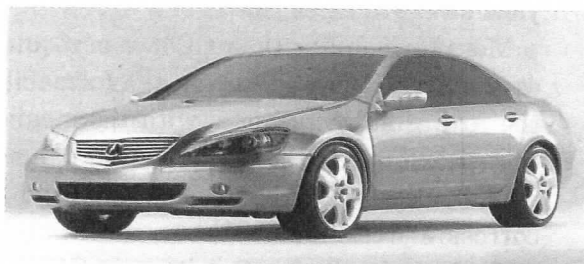

Fig. 17 Fender and trunk-lid of Honda Legend produced by high speed blow forming.

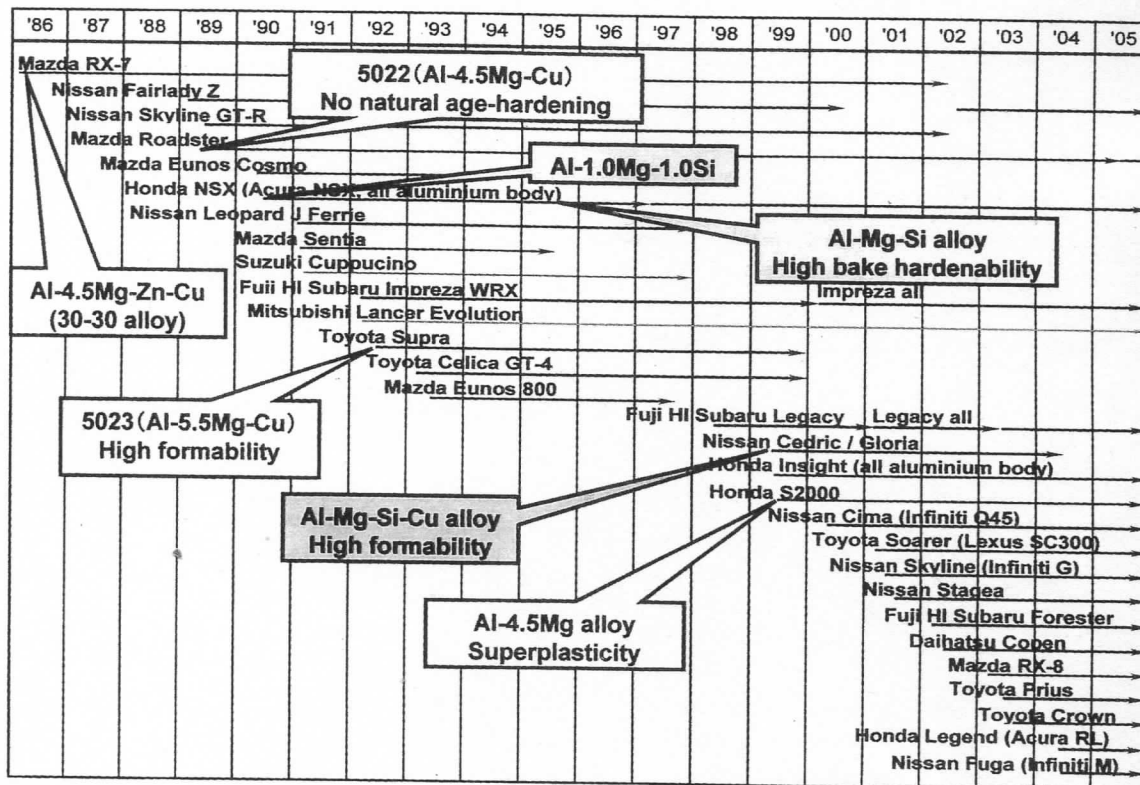

Fig. 18 Development of aluminum body sheet for automobiles in Japan.

stable at 170°C and inhibit the formation of β " which contributes to bake hardening. A new Al-Mg-Si alloy with high bake hardenability, Sumitomo SG112, was applied to the Honda NSX (Fig. 16 (a)) in 1996. Afterward, the Al-Mg-Si-Cu alloy was developed to increase the formability and applied to the Nissan Cedric. In 2003, Sumitomo SG212 alloy (modified SG112) was adopted for the Toyota Prius shown in Fig. 16 (b). Recently, Al-Mg-Si alloys with high bend formability in hemming¹⁹⁾ or with a high r-value related to drawability have been investigated.

6.3 Superplasticity

The formability of aluminum alloys is inferior to mild steel. Thus Honda developed a high temperature blowing machine and used to form the car body. This forming is a kind of super-plasticity. First, they used it for the tank of motorcycles and then the roof of the Honda S2000 with the grain controlled Al-Mg alloy. The merit of this blow forming is the ability to form complex shapes with only one die, female or male. The demerit is the long time of forming compared to press forming. Honda solved this by improving the machine and forming at high pressure. In 2004, Honda applied this high speed blow forming to the fenders and trunk rid of the Honda Legend (Acura RL) shown in Fig. 17²⁰⁾. This blow forming will be widely used to form complex parts. The development of aluminum body sheet for automobiles in Japan is shown in Fig. 18¹⁾.

7. Conclusion

Many alloys have been developed for transportation, such as aircraft, railway cars, motorcycles and automobiles by Sumitomo Light Metals. The Extra Super Duralumin has been the identity of this company. Recently Mitsubishi Heavy Industries made an announcement to begin the production of the Mitsubishi regional jet, MRJ, this November. This news has inspired our metallurgists to invent new alloys such as the ESD.

References

- 1) H. Yoshida : Sumitomo Light Metal Technical Reports, **46** (2005) 99-116.
- 2) I. Igarashi : J. Japan Institute of Metals, **3** (1939) 66-76.
- 3) J. T. Staley : Aluminum Alloys-Contemporary Research and Applications, Ed. by A. K. Vasudevan et al, (Academic Press, 1989), pp. 3-31.
- 4) T. Uno, H. Yoshida and Y. Baba : Aluminum Alloys, Their Physical and Mechanical Properties, Vol. 1, Ed. E. A. Starke, Jr., EMAS, 371-385.
- 5) N. E. Paton and C. H. Hamilton (Rockwell Int. Corp.) : US Patent 4,092, **181** (1978).
- 6) Report of Advanced Aircrafts Technical Development Center, The Society of Japanese Aerospace Companies, Inc. No.802 (1984), No.901 (1985), No.6001 (1986).
- 7) Report of the Development in Aircraft Parts and Materials Industries, The Society of Japanese Aerospace Companies, Inc. No.105 (1987), No.205 (1988), No.307 (1989).
- 8) H. Yoshida et al. : J. de Physique, Collogue C 3, supplement au n°9, 4th Int. Al-Li Conference (1987), C 3-269-275.
- 9) Report of the Development in Aircraft Parts and Materials Industries, The Society of Japanese Aerospace Companies, Inc. No.806 (1994), No.1004 (1996), No.1102 (1997).
- 10) H. Sano and H. Kondo : Proc. 7th Int. Al. Extrusion Technology Seminar, Chicago, (2000), Vol. 1, 167-175.
- 11) H. Yoshida and Y. Baba : J. Japan Institute of Light Metals, **31** (1981), 20-29.
- 12) Y. Baba : Trans. JIM, **7** (1966) 224., Proc. ICSMA, Supplement to Trans. JIM, **9** (1968), 356.
- 13) Y. Baba, et al. : Proceedings of 6th International Leichtmetalltagung, Leoben-Wien, (1975), 99.
- 14) Y. Baba and H. Yoshida : Proc. 2nd Int. Al. Extrusion Technology Seminar, Atlanta, (1977), 301.
- 15) H. Yoshida et al. : J. Japan Institute of Light Metals, **46** (1996), 89-96.
- 16) Sumitomo Light Metal Technical Reports, **40** (1999) 116.
- 17) T. Uno and Y. Baba : SAE Technical Paper Series 800348 (1980)
- 18) H. Uchida and H. Yoshida : J. Japan Institute of Light Metals, **46** (1996), 427-431.
- 19) M. Asano, H. Uchida and H. Yoshida : J. Japan Institute of Light Metals, **52** (2002), 448-452.
- 20) F. Fukuchi et al. : J. Japan Institute of Light Metals, **55** (2005), 147-152.